

# LY

## (IP23)压缩机专用三相异步电动机

### LY Series Screw Compressor Three-phase Asynchronous Motor

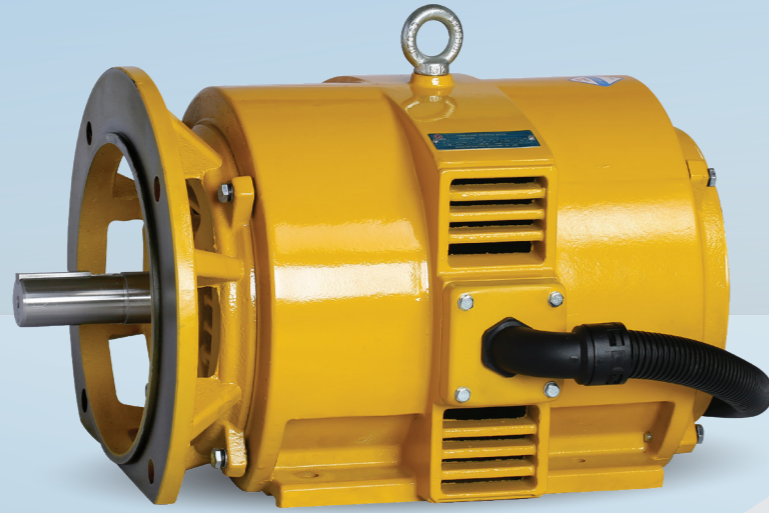

LY系列(IP23)电动机是针对压缩机市场开发的压缩机专用电机。中心高H132-280mm,是防护型自扇冷式笼型转子三相异步电动机,具有高效、节能、起动转矩大、噪声低、振动小、可靠性高等特点,其功率等级及安装尺寸完全符合IEC标准。

LY Series (IP23) Electric Motor is special developed for Compressor. Center height from 132 to 280 mm, with dust protection and air cooling and squirrel cage three phase asynchronous motor, it has features of high efficiency, energy saving, big starting torque. Low noise and vibration, durable performance, its efficiency, power and mounting type comply with IEC standard.

产品型号示例 Sample Product Model

**LY — 250M2 — 2**

极数:2极  
Pole count: 2 poles

规格代号。表示中心高250mm,M机座  
Specification code: 250mm high,M stand

产品代号,表示异步电动机。IP23系列  
Product code: represents asynchronous motor.  
IP23 series.

LY系列(IP23)压缩机专用三相异步电动机安装及外形尺寸图—B3 LY Series Motor Mounting and Overall Dimensions—B3

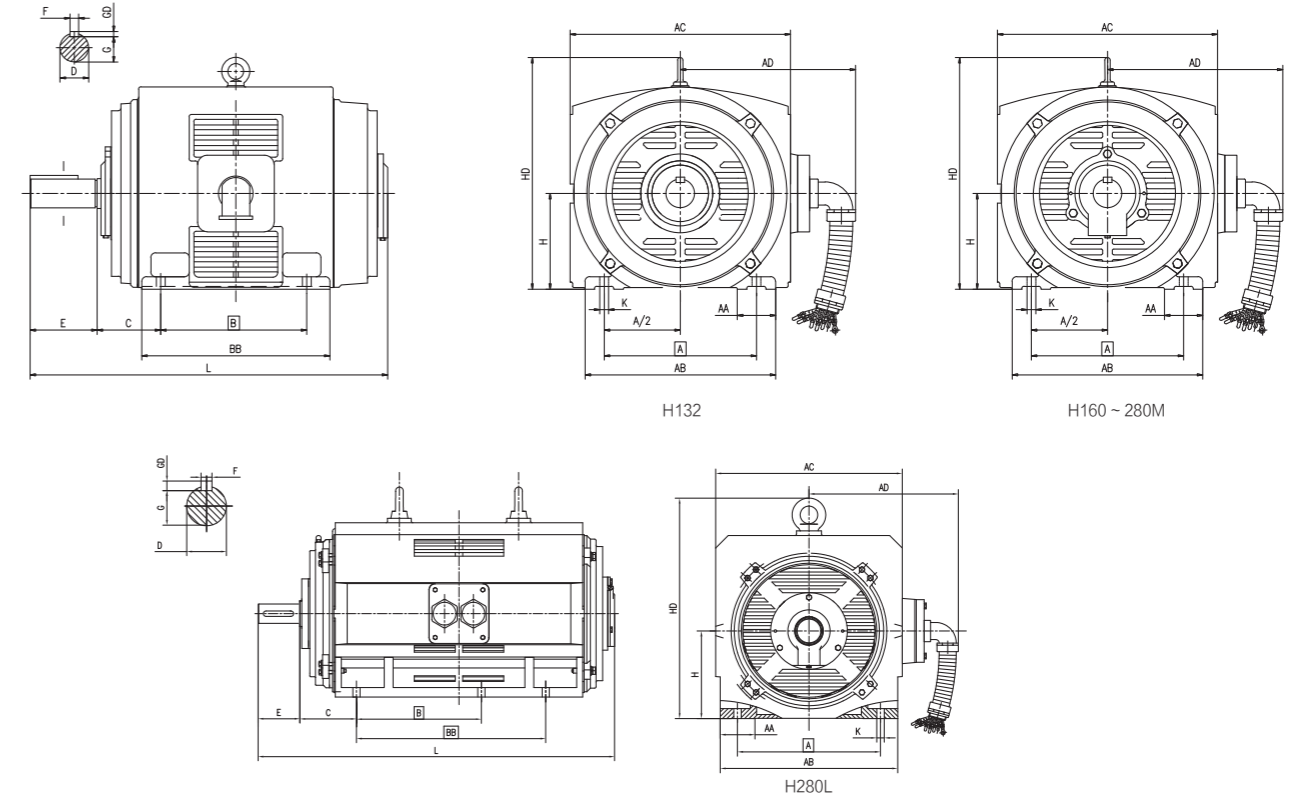

机座号 Frame Size	级 数 Pole	安装尺寸Mounting Dimensions(mm)									外形尺寸Overall Dimensions(mm)						
		A	B	C	D	E	F*GD	G	H	K	AB	AC	AD	AA	BB	HD	L
132M	2	216	210	89	38	80	10*8	33	132	4-φ12	262	325	250	46	302	340	520
160M	2-8	254	210	108	42	110	12*8	37	160	4-φ14.5	330	380	280	75	275	395	600
160L			254														
180M	2-8	279	241	121	55	16*10	49	180			350	420	320	75	320	435	670
180L	2-8		279														
200M	2-8	318	267	133	60	18*11	53	200	4-φ18.5	400	465	340	80	350	490	710	
200L			305											393			750
225M	2	356	311	149	65	140	58	225	4-φ24	510	550	430	100	395	535	750	
	4-8			395													
250S	2	406	168	75	75	20*12	67.5	250	4-φ24	510	550	430	100	415	600	800	
	4-8													455			
250M	2	349	75	65	140	18*11	58	280	4-φ24	570	610	430	110	581	650	950	
	4-8													581			
280M	2	457	419	190	65	140	18*11	58	280	4-φ24	567	595	480	111	581	710	1200
	4-8																
280L	2	457	419	190	80	170	22*14	71	280	4-φ24	567	595	480	111	581	710	1230
	4-8																

注:若有特殊要求,可按用户需求提供。 Please contact us with your requirement.

LY系列(IP23)压缩机专用三相异步电动机安装及外形尺寸图—B35 LY Series Motor Mounting and Overall Dimensions—B35

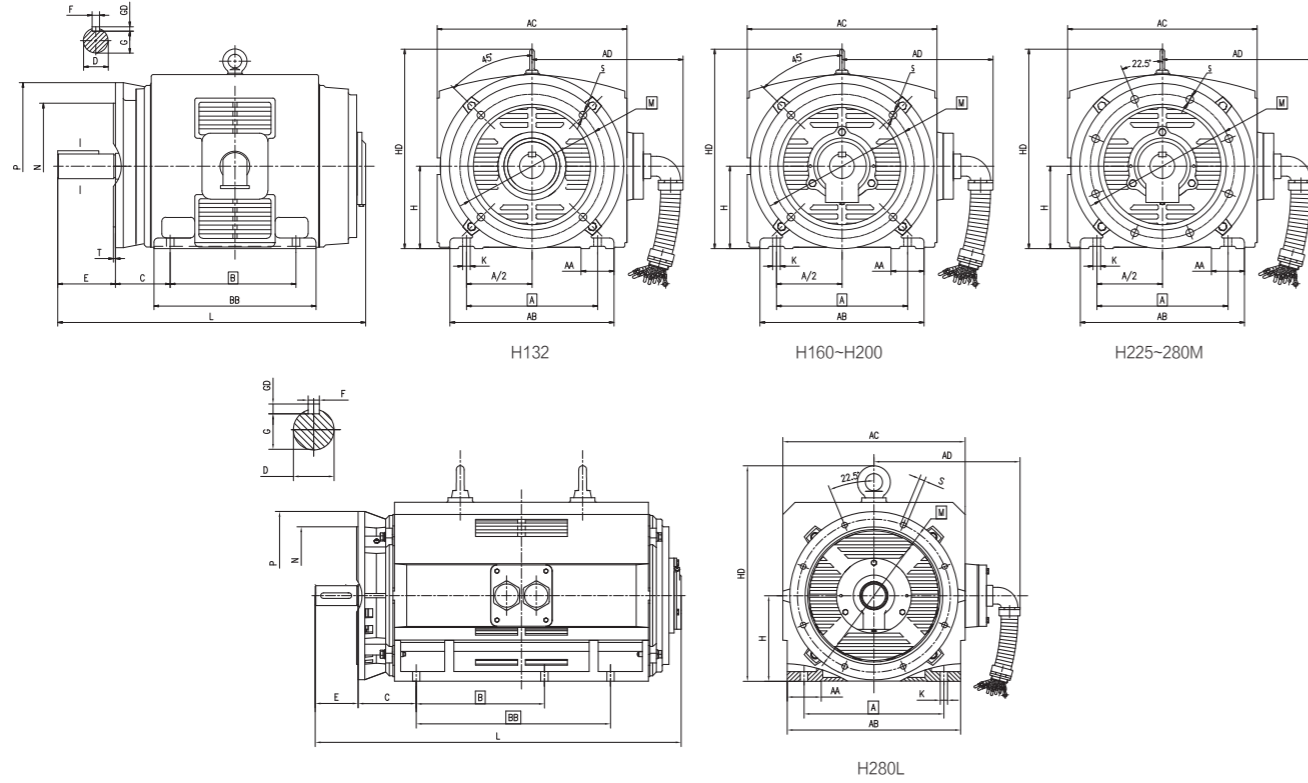

机座号 Frame Size	级数 Pole	安装尺寸Mounting Dimensions(mm)													外形尺寸Overall Dimensions(mm)									
		A	B	C	D	E	F*GD	G	H	K	M	N	P	S	T	AB	AC	AD	AA	BB	HD	L		
132M	2	216	210	121	38	80	10*8	33	132	4-φ12						262	325	250	46	302	340	550		
160M	2-8	254	210	108	42	110	12*8	37	160	4-φ14.5	300	250	350			330	380	280	75	275	395	600		
160L			254																					
180M	2-8	279	241	121	55	110	16*10	49	180	4-φ18.5	350	300	400	5		350	420	320	75	320	435	670		
180L	2-8		279																					
200M	2-8	318	267	133	60	18*11	53	200	4-φ18.5							400	465	340	80	350	490	710		
200L			305																					
225M	2	356	311	149	65	140	18*11	58	225							450	520	390	87	395	535	750		
250S	4-8																							
250M	2	406	349	168	75	140	20*12	67.5	250	4-φ24	500	450	550	8-φ18.5		510	550	430	100	415	600	800		
250M	4-8																							
280S	4-8	457	419	190	80	170	22*14	71	280							570	610	430	110	530	650	950		
280M	2																							
280M	4-8																					980		
280L	2	457	419	190	65	140	18*11	58	280	6-φ24						567	596	480	111	635	710	1200		
280L	4-8																							

注: 若有特殊要求, 可按用户需求提供。 Please contact us with your requirement.

技术数据 Technical Data

型号 Type	额定功率 Output		转速 Speed (r/min)	满载时 电流Current380V(A)			效率 Efficiency η(%)	功率因素 POWER Factor COSΦ	堵转电流 额定电流 Ist/In	堵转转矩 额定转矩 Tst/Tn	最大转矩 输出转矩 Tm/Tn	振动 Vibration	噪声 Noise LwdB(A)	重量 Weight (kg)
	(kW)	(HP)		额定电流	SF=1.15	SF=1.2								
LY-132M1-2	11	15	2920	22.1	25.4	26.5	87.0	0.87	7.0	1.7	2.2	2.8	85	100
LY-132M2-2	15	20	2920	29.4	33.8	35.3	88.0	0.88	7.0	1.7	2.2	2.8	85	110
LY-160L-2	15	20	2940	29.4	33.8	35.3	88.0	0.88	7.0	1.7	2.2	2.8	85	146
LY-160L1-2	18.5	25	2940	35.5	40.8	42.6	89.0	0.89	7.0	1.8	2.2	2.8	85	150
LY-160L2-2	22	30	2940	42.0	48.3	50.4	89.5	0.89	7.0	2.0	2.2	2.8	85	162
LY-160L3-2	30	40	2940	57.2	65.8	68.7	89.5	0.89	7.0	1.7	2.2	2.8	88	170
LY-160M-4	11	15	1460	22.5	25.8	27.0	87.5	0.85	7.0	1.9	2.3	1.8	76	132
LY-160L1-4	15	20	1460	30.1	34.6	36.1	88.0	0.86	7.0	2.0	2.3	1.8	80	144
LY-160L2-4	18.5	30	1460	36.7	42.2	44.1	89.0	0.86	7.0	2.0	2.3	1.8	80	157
LY-180L1-2	30	40	2940	57.2	65.8	68.7	89.5	0.89	7.0	1.7	2.2	2.8	88	190
LY-180L2-2	37	50	2940	69.8	80.3	83.8	90.5	0.89	7.0	1.9	2.2	2.8	88	227
LY-180L3-2	45	60	2940	84.4	97.1	101.3	91.0	0.89	7.0	2.0	2.2	2.8	90	240
LY-180M-4	22	30	1460	43.4	49.9	52.1	89.5	0.86	7.0	1.9	2.3	1.8	80	212
LY-180L-4	30	40	1460	57.9	66.6	69.5	90.5	0.87	7.5	1.9	2.3	1.8	84	230
LY-200L1-2	45	60	2940	84.4	97.1	101.3	91.0	0.89	7.0	1.9	2.2	2.8	90	308
LY-200L2-2	55	75	2940	102.6	118.0	123.1	91.5	0.89	7.0	1.9	2.2	2.8	90	330
LY-200M-4	37	50	1465	71.4	82.1	85.7	90.5	0.87	7.0	2.0	2.3	2.8	87	275
LY-200L-4	45	60	1465	85.9	98.8	103.1	91.5	0.87	7.0	2.0	2.3	2.8	87	365
LY-225M1-2	55	75	2960	102.6	118.0	123.1	91.5	0.89	7.0	1.9	2.2	2.8	90	374
LY-225M2-2	75	100	2960	139.9	160.9	167.9	91.5	0.89	6.7	1.8	2.2	2.8	92	370
LY-225M-4	55	75	1475	105.0	120.7	126.0	91.5	0.88	7.0	1.8	2.2	2.8	88	380
LY-250M1-2	90	120	2970	167.0	192.1	200.4	92.0	0.89	6.8	1.7	2.2	4.5	96	490
LY-250M2-2	110	150	2970	200.8	230.9	240.9	92.5	0.9	6.8	1.7	2.2	4.5	96	520
LY-250M3-2	132	180	2970	240.9	277.0	289.1	92.5	0.9	6.8	1.6	2.2	4.5	98	545
LY-250S-4	75	100	1480	140.8	161.9	168.9	92.0	0.88	6.7	2.0	2.3	4.5	89	431
LY-250M-4	90	120	1480	168.0	193.2	201.6	92.5	0.88	6.7	2.2	2.3	4.5	89	478
LY-280M1-2	110	150	2970	200.8	230.9	240.9	92.5	0.9	6.8	1.7	2.2	4.5	96	610
LY-280M2-2	132	180	2970	240.9	277.0	289.1	92.5	0.9	6.8	1.6	2.2	4.5	98	670
LY-280M3-2	160	215	2970	292.0	335.8	350.4	92.5	0.9	6.8	1.4	2.0	4.5	102	730
LY-280L1-2	185	250	2970	337.6	388.3	405.2	92.5	0.9	6.8	1.4	2.0	4.5	102	1020
LY-280L2-2	200	270	2970	363.1	417.5	435.7	93.0	0.9	6.8	1.4	2.0	4.5	102	1045
LY-280L3-2	220	300	2970	397.2	456.8	476.7	93.5	0.9	6.8	1.4	2.0	4.5	102	1080
LY-280L4-2	250	335	2970	460.2	529.2	552.2	93.8	0.88	6.8	1.2	2.0	4.5	102	1100
LY-280S-4	110	150	1480	205.3	236.1	246.4	92.5	0.88	6.8	1.7	2.3	4.5	92	640
LY-280M-4	132	180	1480	245.1	281.8	294.1	93.0	0.88	6.8	1.8	2.3	4.5	92	680

注: 若有特殊要求, 可按用户需求提供。 Please contact us with your requirement.